



International Filter Products

Revolutionary systems for your industry

PureFlo® SKL Series PES 0.65 µm/0.2 µm – Dual Layer Filter Capsules

SKL Series Dual Layer PES filter capsule with all polypropylene construction provides excellent chemical compatibility and superior flow per unit area as compared to other membrane capsules. The PES filter capsules have been specially designed for sterilizing in biopharmaceutical and sterile compounding applications. The filters come with a pre-layer configuration, which increases the filtration volume significantly (up to 25%). The hydrophilic PES membrane does not require pre-wetting agents, thereby eliminating a potential source of contamination. The PES membrane is a low protein binding media. The capsules were designed with built-in luer loc caps for simple and efficient evacuation of air and liquid. The units are used for the filtration of small to medium volumes used in production, laboratory, and pilot runs. No adhesives, binders, or surfactants are used in the manufacturing process of these capsules. The filters are manufactured in accordance with GMP and comply with <USP 797> guidelines. The filters are flushed with pharmaceutical-grade purified pyrogens-free water, and 100% integrity tested prior to dispatch. Our filters are free from animal-derived components raw materials can be traced by Lot Number and are strictly regulated maintaining ISO 13485 & ISO 14001 quality standards.

PureFlo® SKL Filter Capsules



LFLM Connections

Inlet:

Female Luer Lock

Outlet:

Male Luer Lock



International Filter Products
Revolutionary systems for your industry



www.internationalfilterproducts.com

7914 Ajay Drive,
Sun Valley, California, 91352
Phone: 818-504-8115

Email: sales@internationalfilterproducts.com





International Filter Products

Revolutionary systems for your industry

Application

- Buffers and Media
- SVP (Small Volume Parenteral)
- Vaccines
- Scale up processing
- Product Sterilization
- Bio Bags Compatible
- Biologics
- Ultrapure Water
- Fermentation Broths
- Pharmaceuticals
- Antibiotics
- Serums

Technical Data Sheet

Micron Rating:

Final Membrane: 0.2 μm PES [Sterilizing Grade Membrane]

Pre-Filter: Highly Asymmetric 0.65 μm PES

Effective Filtration Area:

L-Size; 2.7 ft^2 , (2,550 cm^2)

Materials of Construction:

Membrane: Pharmaceutical Grade PES (Polyethersulfone) Sterilizing Grade

Membrane Feature: Hydrophilic, Low Protein Binding, High Flow Rate

Shell, Cage, Core, End Caps: Polypropylene

Sealing: Thermally Bonded

Operating Conditions:

Maximum Operating Pressure:

Liquid: 5.5 bar (80psi) at 72°F/22°C

Gas: 4.1 bar (60psi) at 72°F/22°C

Minimum Burst Pressure: 8.3 bar (120psi) at 72°F/22°C

Maximum Forward Differential Pressure: 5.0 bar (72psi) at 72°F/22°C

Maximum Reverse Differential Pressure: 2.1 bar (30psi) at 72°F/22°C

Maximum Operating Temperature: 176°F/80°C



International Filter Products
Revolutionary systems for your industry



www.internationalfilterproducts.com

7914 Ajay Drive,
Sun Valley, California, 91352
Phone: 818-504-8115

Email: sales@internationalfilterproducts.com





International Filter Products

Revolutionary systems for your industry

Nominal Dimension:

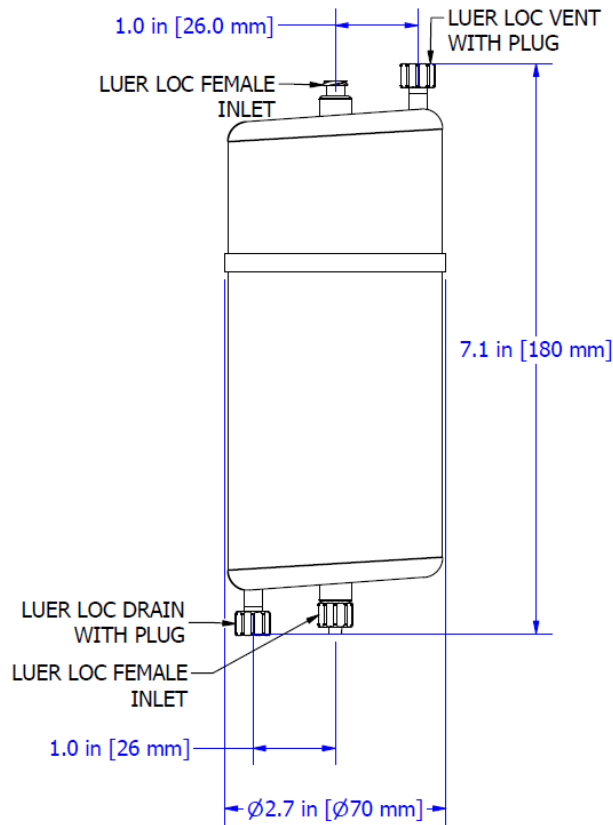

Typical Filtered Volume:

30.0L – 100.0L

[Aqueous and alcohol base solutions]

*Volume Filtered is an estimated range for Sterile Compounding, Pharmaceutical & Biological applications. The Filtration Volume is significantly influenced by your solution's viscosity, active ingredients, etc., properties. The best way to determine the exact filtration volume per filter is to try it with your solution.

Hold-Up Volume (Approx.):

Upstream Volume: 128 ml

Downstream Volume: 20 ml

Filter Integrity:

The finished product was sampled and shown to exhibit a minimum bubble point of ≥ 18 psi (1.2 bar) in 60%IPA / 40% water, ≥ 17.5 psi (1.2 bar) in 70%IPA / 30% water, and ≥ 50 psi (3.5 bar) in DI Water (at 22°C).





International Filter Products

Revolutionary systems for your industry

Bacterial Retention ASTM F838-05:

The filters are quantitatively retentive towards *Brevundimonas diminuta* (ATCC #19146) at a minimum challenge level of 10^7 CFU per cm^2 of filtration area, consistent with ASTM F838-05

Sterilization:

International Filter Products typically stocks ETO Sterilized [factory sterilized] filter capsules. Few sterilization methods are mentioned below:

Capsules can be autoclaved 25 times at 125 °C (257°F) for 30 minutes or chemically sanitized in situ using common sanitizing agents or hot water at 90 °C (194°F) for a limited time (dependent on time and temperature).

They can also be ETO sterilized, and the Ethylene Oxide (ETO) Sterilization Process must comply with ISO 10993-7:2008 Biological Evaluation of Medical Devices - Part 7. Each filter is subjected to a validated ETO process. Sterilization of the fluid path must be validated per ANSI/AAMI/ISO 11135 which provides a minimum sterility assurance level (SAL) of 10^{-6} .

Warning: The filters cannot be sterilized by steam-in-place (SIP) and Gamma Irradiation.

Regulatory Compliance 21CFR Part 177 & USP <88>:

The filters are constructed with polypropylene resins and filtration media in compliance with 21CFR Part 177 of the US Code of Federal Regulations and USP Class VI Biological USP <88> Test for Plastic.

USP <85> Bacterial Endotoxins:

The filters were tested to confirm that an aqueous extraction of this product contains <0.25 EU/ml as determined by the Limulus Amebocyte Lysate (LAL) Test

USP <645> Conductivity USP:

Effluent is tested during the manufacturing process and shown to meet the requirements for USP Sterile Water for Injection for conductivity.

USP <87> / ISO 10993-5 Cytotoxicity:

Extract from this product is non-Cytotoxic.

Hemolysis ASTM F756-17:

Extract from this product is non-Hemolytic.

Human and Veterinarian Use:

The product is safe for Human and Veterinarian use. CGMP CFR part 210 & 211, additional requirements of 21 CFR part 600 and 21 CFR part 680 are applicable to the aseptic manufacturing process.

Animal-Derived Components & TSE/BSE Risk:

No animal-derived material is intentionally added or used during the manufacture of this product.

Shelf Life:

The SKL capsules have a shelf life of 3 years from the date of sterilization.

Ethylene Oxide (ETO) Sterilized product packaging provides adequate protection to maintain a sterile barrier throughout the product's distribution, handling, and 3-year shelf life.





International Filter Products

Revolutionary systems for your industry

SKL- Series PES Mid-Size Capsules (Pharmaceutical Grade)

Ordering Guide



[1]	[2]	[3] Inlet and [4] Outlet	[5]
Micron Rating [Pre-Filter/Final Filter]	Filter Size Code [Filtration Area]	Inlet and Outlet Connection	Sterilization
<ul style="list-style-type: none"> DS065S020 : Highly Asymmetric 0.65/0.2 μm <p>Note: All final membranes are sterilizing grade.</p>	<ul style="list-style-type: none"> L <p>[Filtration Area: 2,550 cm²]</p>	<ul style="list-style-type: none"> LF : Female Luer Lock LM : Male Luer Lock 	<p>-ETO</p> <p>Ethylene Oxide Sterilization</p>

Example:

SKLDS065S020LLFLM-PH-ETO

PureFlo® SKL Series Capsule, Highly Asymmetric Dual Layer PES 0.65μm / 0.2μm PES membrane (Sterilizing Grade), 5.0", L-Size, Filtration Area 2,550 cm², Female Luer Lock Inlet, Male Luer Lock Outlet, ETO Sterilized (Factory Sterilized)

Part Number

Description





International Filter Products

Revolutionary systems for your industry

Special Configuration:

Layer Option:

- Dual Layer

Micron Rating Option:

- 0.04 Micron
- 0.1 Micron
- 0.2 Micron
- 0.45 Micron
- 0.65 Micron
- 0.8 Micron
- 1.2 Micron

Inlet Fitting Option:

- 1H : 1/8" Hose Barb
- 1Q : 1/8" Male Quick Coupling with Metal Latch
- 2H : 1/4" Hose Barbs
- 2H-FB : 1/4" Hose barbs with Filling Bell
- 2Q : 1/4" Male Quick Coupling for Metal Latch
- 2N : 1/4" MNPT
- 3H : 3/8" Hose Barbs
- LF : Luer Loc Female
- MT : 1/2" Tri-Clamp

Outlet Fitting Option:

- 1H : 1/8" Hose Barb
- 1Q : 1/8" Male Quick Coupling with Metal Latch
- 2H : 1/4" Hose Barbs
- 2H-FB : 1/4" Hose barbs with Filling Bell
- 2Q : 1/4" Male Quick Coupling for Metal Latch
- 2N : 1/4" MNPT
- 3H : 3/8" Hose Barbs
- LM : Luer Loc Male
- MT : 1/2" Tri-Clamp

