



## STERILE CAPSULE FILTER

These filters are designed for applications where sterility of the affluent is mandatory (Sterile Compounding and Pharmaceutical use). The product contains a pharmaceutical grade PTFE membrane (Sterilizing Grade) and the filters are built in a 10,000-class clean room, flushed, dried and 100% integrity tested prior to packaging. The product is factory sterilized by Ethylene Oxide gas (ETO) ensuring sterility.

## Technical Data Sheet

**Catalog Number: MKPF045020DLFLM-ETO**



### **Materials of Construction**

**Filter Membrane:** 0.45 um Pre-filter /0.2 um Final Pharmaceutical Grade PTFE Sterilizing Grade - Hydrophobic

**Supports:** Polypropylene

**Core:** Polypropylene

**Capsule Body:** Polypropylene

### **Filter Dimensions and Specifications**

**Outer Diameter:** 59 mm (2.32")

**Length, Fitting to Fitting:** 92 mm (3.62")

**Filter Area:** 480 cm<sup>2</sup> (74.4 in<sup>2</sup>)

**Sterilization:** The filter is factory sterilized by Ethylene Oxide Gas (ETO)

**Inlet Fitting:** Luer Loc Female

**Outlet Fitting:** Luer Loc Male

**Volume Filtered:** 12.3 L to 23.1 L

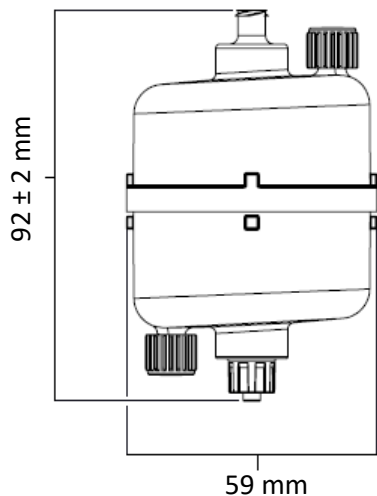

### Integrity Data

Pore Size	Min, Bubble Point, 25°C	Challenge Microorganisms	CFU per cm <sup>2</sup>
0.20 µm	≥3.5 bar (50 psi)	Brevundimonas Diminuta (ATCC 19146)	7

### Operating Parameters

Maximum Working Pressure: 5.5 bar (80 Psi) @ 25 °C (77 °F)

Maximum differential Pressure (forward): 4.1 bar (60 Psi) @ 25 °C (77 °F)

Maximum differential Pressure (reverse): 2.1 bar (30 Psi) @ 25 °C (77 °F)

Maximum Operating Temperature: 80 °C (176 °F)

Recommended Replacement Pressure: 2.4 bar (35.3 Psi)

### Safety

- UPS Bacteria Endotoxins: ≤25 EU/ml
- Factory Sterilized: Ethylene Oxide Gas (ETO)
- Product was 100% Integrity Tested and flushed with filtered water @ 0.05 µm

### Regulatory

- Complies with USP 797 Guidelines
- ASTM F838-05 - Bacterial Retention
- FDA 21 CFR 177.1655
- USP Class VI - Biological Reactivity
- ISO 10993-Part 1.5 - Cytotoxicity
- ISO 14001; ISO 13485; OHSMS 18001 Certified.
- ASTM Hemolysis testing
- Human/Veterinarian Use – Applies when the requirements from CGMP CFR part 210 and 211 and additional requirement 21 CFR part 600 and 21 CFR part 680 are used in the aseptic processing.